



Model: CRC-400/800/825/850 (Structural) Roof Curb

Standard Construction:

18ga. Galvanized steel construction with 2 x 2 pressure-treated wood nailers. 1 1/2" thick 3# density rigid insulation. Internal reinforcing. 2" mounting flange. All welds micro-sealed and prime painted after fabrication.

Added Options (When Required):

RPI Job #: -

Project: _____

Architect: _____

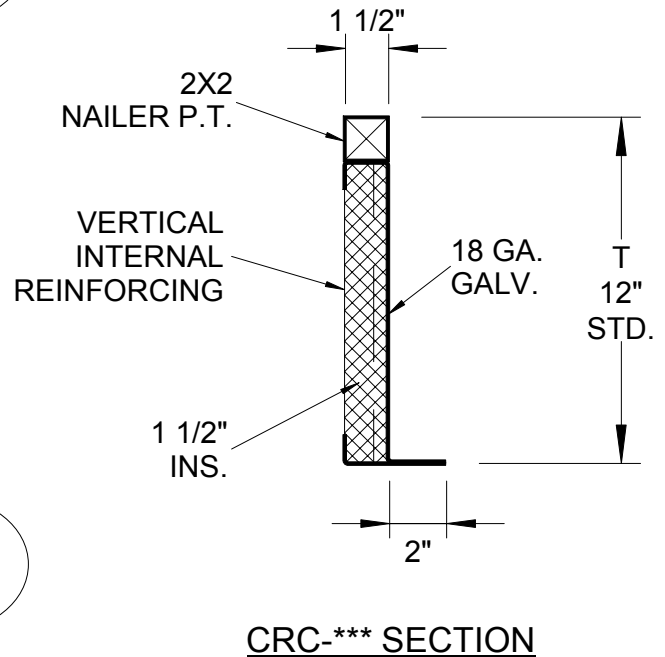
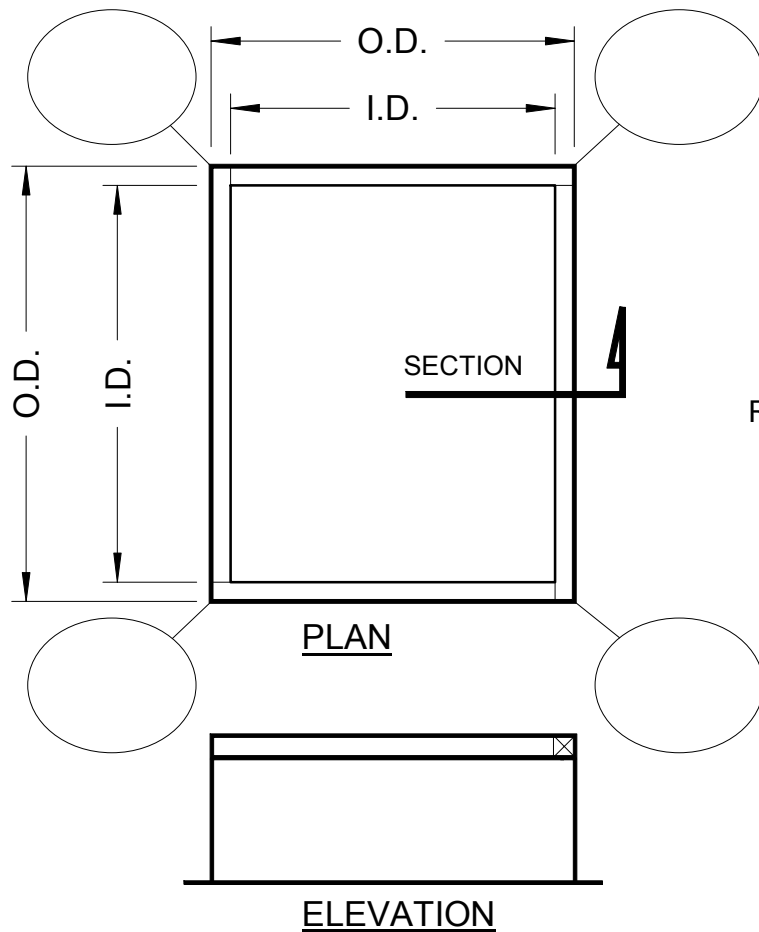

Qty.	I.D.	O.D.	T	Tag:
	46 1/2" x 46 1/2"	49 1/2" x 49 1/2"		CRC-400
	48" x 96"	51" x 99"		CRC-800
	46 1/4" x 90 1/4"	49 1/4" x 93 1/4"		CRC-825
	46 1/2" x 92 1/2"	49 1/2" x 95 1/2"		CRC-850